

DIN 41612

TYPE HALF R (REVERSED) - MALE

- 16, 24, 32 and 48 Contacts
- 3 Rows
- Class 2 and 3
- 2.54mm(0.1"), 5.08mm(0.2" Half loaded) Pitch
- High Reliability
- UL Approved

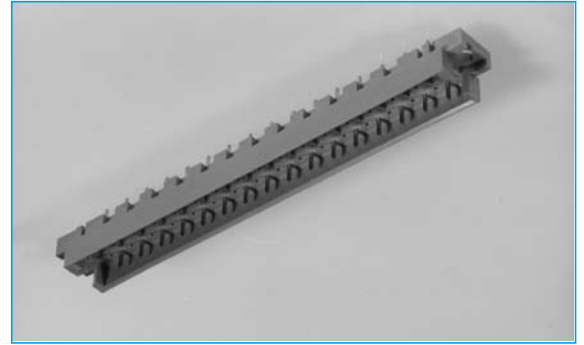

SPECIFICATION

Material

Insulator: Glass filled polyester (PBT, UL flammability 94V-0)

Contacts: Female copper alloy, male brass

Contact finish: Contact area: Gold over nickel (per requirements of performance class 3, class 2)
Termination area: Tin - plated or Gold-plated for long wrap post

Mechanical

Insertion force: 48 contacts max. 45N
32 contacts max. 30N
16 contacts max. 15N
Withdrawal force per contact: min 0.15N

Temperature range: -55°C to +125°C
Air and creepage distance 1.2mm min.

Electrical

Current rating: 20°C 2A
70°C 1A
100°C 0.5A

Contact resistance: ≤20mΩ (testing current 100mA)
≤40mΩ after 400 mating cycles

Capacitance between adjacent contacts: Appr. 2pF

Insulation resistance: ≥10¹²Ω
(between adjacent contacts at 100 VDC)

Test voltage: 1,000Vrms between contacts (2.54mm spacing)
1,550Vrms between contacts (5.08mm spacing)
1,550Vrms between contacts and body

Operating voltage: 250V AC

Agency approval

U/L Electric rating: 250V, 2A
Mating Cycles: Class 2 = 400 Class 3 = 50

OUTLINE DRAWING

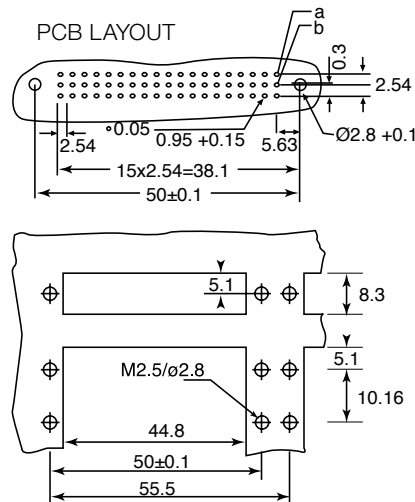
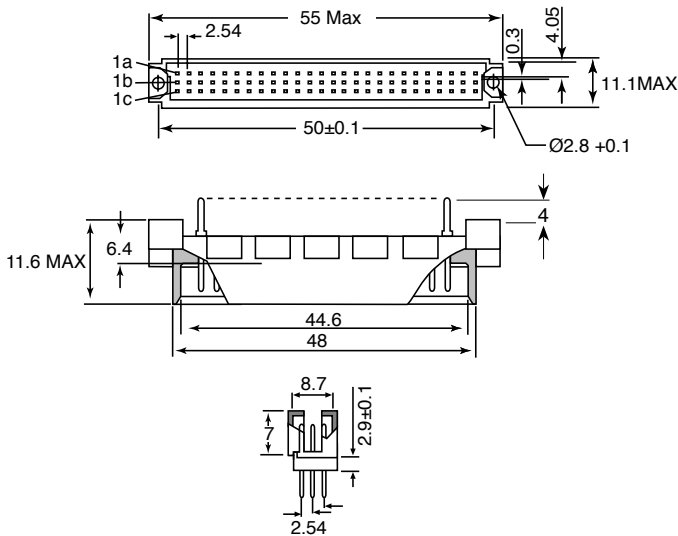

a + b + c	
a + c	
a + b	
a	
a + b + c All even no.	
a + c All even no.	

ORDERING INFORMATION

DBC	DIN	M	16	HR	A	S	3
Dubilier Connectors	Series DIN 41612	Connector Type M = Male	N° of Ways 16 = 16 ways 24 = 24 ways 32 = 32 ways 48 = 48 ways	Housing Style HR = Half R	Position of Contacts A, AB, AC, ABC, ABC1 = A+B+C even n°. AC1=AC even n°.	Termination Style S = Straight Solder Tail length options available on request	Quality Class 3 = class 3 2 = class 2

DIN 41612

TYPE HALF R (REVERSED) – FEMALE

- 16, 24, 32 and 48 Contacts
- 3 Rows
- Class 2 and 3
- 2.54mm(0.1"), 5.08mm(0.2" Half loaded) Pitch
- High Reliability
- UL Approved

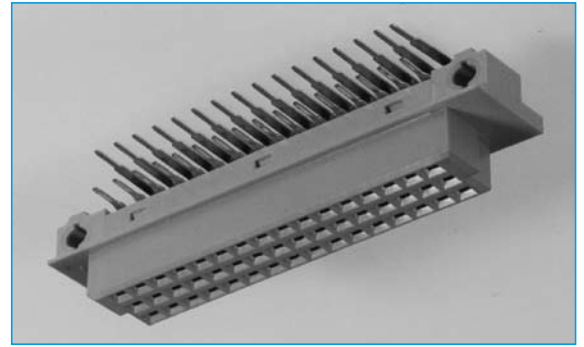

SPECIFICATION

Material

Insulator: Glass filled polyester (PBT, UL flammability 94V-0)

Contacts: Female copper alloy, male brass

Contact finish: Contact area: Gold over nickel (per requirements of performance class 3, class 2)
Termination area: Tin - plated or Gold-plated for long wrap post

Mechanical

Insertion force: 48 contacts max. 45N
32 contacts max. 30N
16 contacts max. 15N
Withdrawal force per contact: min 0.15N

Temperature range: -55°C to +125°C
Air and creepage distance 1.2mm min.

Electrical

Current rating: 20°C 2A
70°C 1A
100°C 0.5A

Contact resistance: ≤20mΩ (testing current 100mA)
≤40mΩ after 400 mating cycles

Capacitance between adjacent contacts: Appr. 2pF

Insulation resistance: ≥10¹²Ω
(between adjacent contacts at 100 VDC)

Test voltage: 1,000Vrms between contacts (2.54mm spacing)
1,550Vrms between contacts (5.08mm spacing)
1,550Vrms between contacts and body

Operating voltage: 250V AC

Agency approval
U/L Electric rating: 250V, 2A
Mating Cycles: Class 2 = 400 Class 3 = 50

SECTION 10

OUTLINE DRAWING

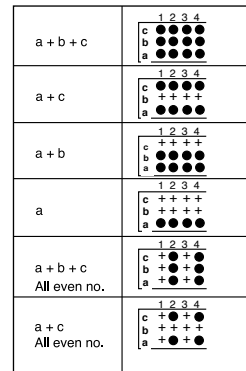
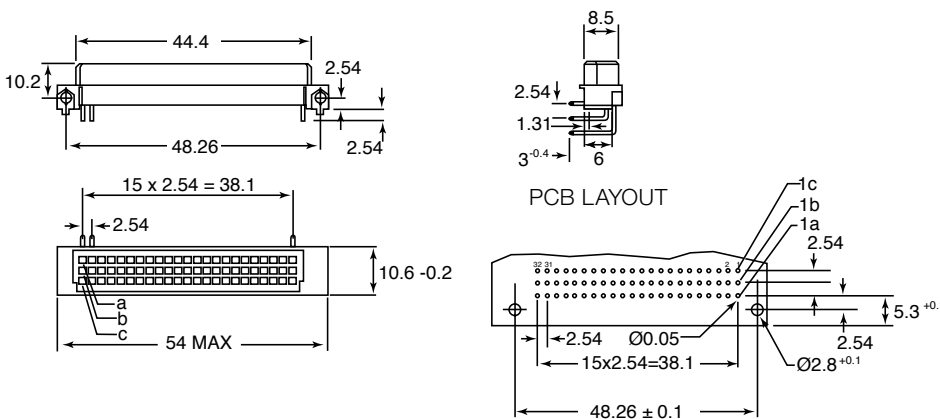

ORDERING INFORMATION

DBC	DIN	F	16	HR	A	RA	3
Dubilier Connectors	Series DIN 41612	Connector Type F = Female	N° of Ways 16 = 16 ways 24 = 24 ways 32 = 32 ways 48 = 48 ways	Housing Style HR = Half R	Position of Contacts A, AB, AC, ABC, ABC1 = A+B+C even n°. AC1=AC even n°.	Termination Style RA = Right Angled Solder	Quality Class 3 = class 3 2 = class 2