

CAPACITORS

TANTALUM DIPPED SH

SECTION 1

The 'SH' is a premium grade tantalum capacitor, exhibiting ultra-low leakage-current and impedance in small case sizes.

Applications for this device include:-

- High density logic boards - where space is a premium
- Instrumentation - requiring high temperature stability
- Timing circuits - requiring low leakage current
- Decoupling circuits - requiring low impedance

Product is normally supplied loose on a 5mm pitch, but it is also available with a 2.5mm pitch and also taped & reeled for auto-insertion.

All product is manufactured to comply with Dubilier's stringent quality standards involving quality checks at each stage of processing and production.

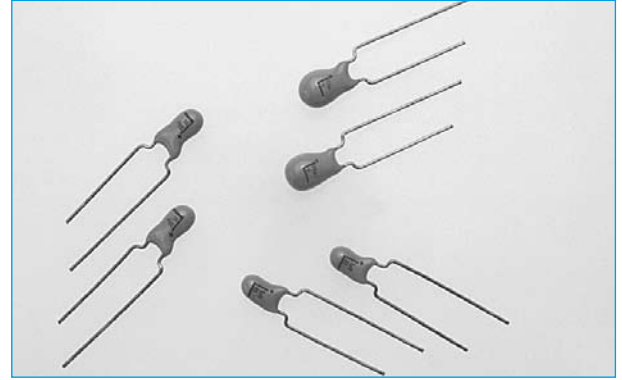

RANGE

V	6.3	10	16	25	35	50
μF	øxL/mm	øxL/mm	øxL/mm	øxL/mm	øxL/mm	øxL/mm
0.1				→	4.5x7.0	4.5x7.0
0.15				→	4.5x7.0	4.5x7.0
0.22				→	4.5x7.0	4.5x7.0
0.33				→	4.5x7.0	4.5x7.0
0.47				→	4.5x7.0	4.5x7.0
0.68				→	4.5x7.0	4.5x7.0
1.0			→	4.5x7.0	4.5x7.0	5.0x8.5
1.5	→	→	4.5x7.0	4.5x7.0	4.5x7.0	5.0x9.0
2.2	→	4.5x7.0	4.5x7.0	4.5x7.0	4.5x7.5	5.5x8.5
3.3	4.5x7.0	4.5x7.0	4.5x7.0	4.5x7.5	5.0x8.5	6.0x10.0
4.7	4.5x7.0	4.5x7.0	4.5x7.5	5.0x8.5	5.5x8.5	6.5x10.0
6.8	4.5x7.0	4.5x7.5	5.0x8.5	5.0x9.0	6.0x8.5	7.0x10.5
10	4.5x7.5	5.0x8.5	5.0x9.0	5.5x9.0	6.0x10.0	8.0x13
15	5.0x8.5	5.0x9.0	5.5x8.5	6.0x10.0	7.0x10.5	8.5x14
22	5.0x9.0	5.5x8.5	6.0x10.0	7.0x10.5	8.0x12.5	9.0x14
33	5.5x8.5	6.0x9.0	6.0x10.0	8.0x12.0	9.0x14.0	
47	6.0x10.0	6.5x10.0	8.0x12.0	9.0x14.0	9.0x15.0	
68	6.5x10.0	7.0x10.5	9.0x12.0	9.0x16		
100	7.0x10.5	8.0x12.5	9.0x16			
150	8.0x12.5	9.0x14.5	9.0x16			
220	9.0x14.0	10.0x17	10.0x18.5			
330	10.0x17	10.0x18.5				

All parts supplied with 5mm pitch as standard. 2.5mm pitch also available on parts with 7mm diameter or less.

SPECIFICATION

Temperature	-55 to +85°C (125°C operation possible with de-rating)
Life Time	2000 Hours @ +85°C
Tolerance	± 20% (10% available)
Leakage Current	<0.008CV or 0.05μA whichever larger (>2 mins.)

ORDERING INFORMATION

SH	10	16	TR
Range	Capacitance μF	Voltage V	Options: TR = Tape/Reel k = 10% Tol 2.5P : 2.5 pitch Blank = 5mm pitch

ENDURANCE

Test Time/Hr 2000 ± 48
Leakage Current/μA Less than 125% of initial value
Capacitance/μF Within ± 10% of initial value
Tan δ Less than or equal to initial value

TAN δ

Capacitance/μF	0.1 to 1.5	2.2 to 6.8	10 to 68	100 to 220
Tan δ	0.04	0.06	0.08	0.1

IMPEDANCE (ohms MAX.)

μF	V	6.3	10	16	25	35	50
0.1						26.0	26.0
0.15						21.0	21.0
0.22						17.0	17.0
0.33						15.0	15.0
0.47						13.0	13.0
0.68						10.0	10.0
1.0					10.0	8.0	8.0
1.5				10.0	8.0	6.0	5.0
2.2			13.0	8.0	6.0	5.0	3.5
3.3	13.0	10.0	6.0	5.0	4.0	3.0	3.0
4.7	10.0	8.0	5.0	4.0	3.0	2.5	2.5
6.8	8.0	6.0	4.0	3.1	2.5	2.0	2.0
10	6.0	5.0	3.2	2.5	2.0	1.6	1.6
15	5.0	3.7	2.5	2.0	1.6	1.2	1.2
22	3.7	2.7	2.0	1.5	1.3	1.0	1.0
33	3.0	2.1	1.6	1.2	1.0	0.8	0.8
47	2.0	1.7	1.3	1.0	0.8		
68	1.8	1.3	1.0	0.8			
100	1.6	1.0	0.8				
150	0.9	0.8	0.6				
220	0.9	0.6	0.5				
330	0.7	0.5					

Impedance measured at 100KHz and 25°C.

ELECTRICAL

Stability at Temperature Extremes -55°C Capacitance within ± 12% max (better than -5% typ) +85°C Capacitance within ± 12% max (better than +5% typ). Leakage current within 10% initial value.

Humidity 40°C, 90-95% RH 21 days Capacitance within 10% of initial value. Leakage current within 125% of initial value. Tan δ less than or equal to initial value.

Shelf Life Capacitance within 10% of initial value.

2000Hr @ 85°C; no voltage applied Leakage current within 125% of initial value. Tan δ less than or equal to initial value.

Surge Voltage 1000 cycles @ 85°C Capacitance within 5% of initial value. Leakage current less than or equal to initial value. Tan δ less than or equal to initial value.

Rated Voltage/V	6.3	10	16	25	35	50
Surge Voltage/V	8	13	20	32	44	63
Temperature - Voltage de-rating @ 125°C	6.3	10	16	25	35	50
	4	6.3	10	16	23	33

SAFETY

Operating Properties

It is recommended that the following operating modes are not imposed on the capacitors;

- Over or reverse voltage
- Over temperature
- Power rating exceeded
- High current surge due to low impedance (we recommend that the circuit impedance should be 3Ω/V minimum).

Material Content

Tantalum capacitors contain no material normally considered as hazardous. Materials include: Epoxy Resin, Graphite, Manganese Dioxide, Tantalum, Tantalum Oxide. Noxious fumes may be emitted if incinerated.

OUTLINE DRAWING

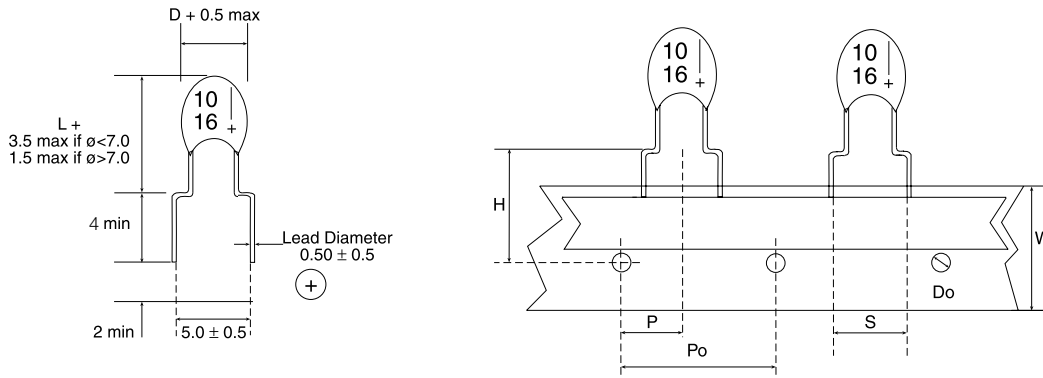

DIMENSIONS (mm)

Code	Description	Dimensions/mm
Po	Feed hole pitch	12.7 ± 0.3
P	Hole centre to component centre	6.35 ± 0.4
S	Lead pitch	$5.0 + 0.8/-0.2$ ($2.5 + 0.4/-0.1$ option)
H	Height to seating plane	16.0 ± 0.5
Do	Feed hole diameter	4.0 ± 0.2
W	Tape width	$18.0 + 1.0/-0.5$

CHARACTERISTICS

DC leakage current (DCL) increases with increasing temperature according to the typical curve

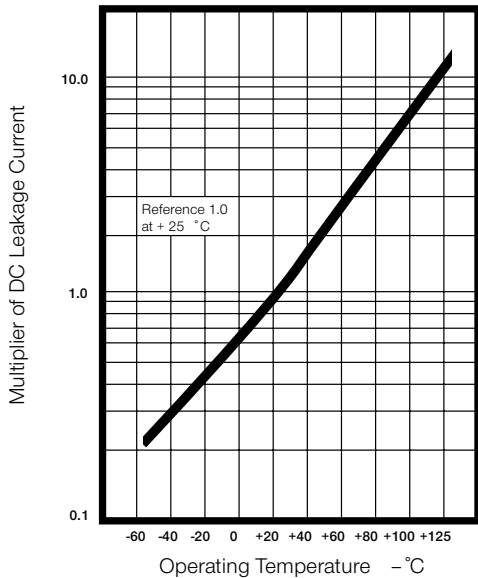

Typical Effect of Temperature upon DC Leakage Current

Capacitance typically changes with temperature according to the curve

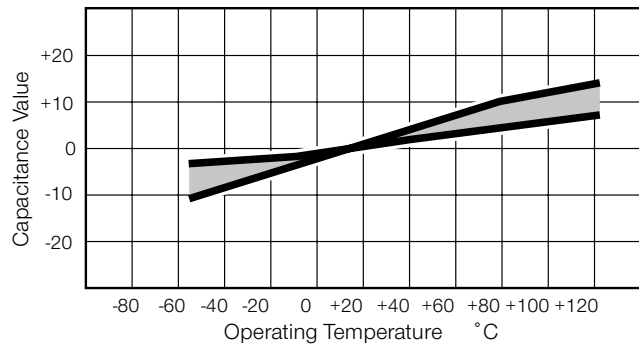

Optimum Solder Wave Profile

