

AUDIO

PCB 6.4 Ø HEADPHONE JACK

SECTION 6

- Competitively priced
- Industry Compatible
- PCB Mounting
- Available in plastic or metal bushing



SPECIFICATION

Contact resistance (DCR 0.1A)

1, Initial, before any testing:

- (1) Between the terminals (NC): 30mΩ
- (2) Plug to sleeve, tip ,ring (NO) contact: 50mΩ

2, After life test with mating plug:

- (1) Between the terminals (NC): 60mΩ
- (2) Plug to sleeve, tip, ring (NO) contact: 100mΩ

Insertation Force:

0.3kg - 3.0kg

Terminals must withstand a 500g minimum pull for 10 seconds

Extraction Force:

0.3kg - 3.0kg

before movement or break from housing occurs

Soldering Heat:

Terminal for PC board temperature: 260 ± 5 °C for 5 ± 1.0 seconds

Operating Temperature range:

-25 °C to 100 °C

Insulating Resistance:

More than 100MΩ by 500v DC at 90 - 95% RH, 40 °C

Voltage Test:

Withstand 0.5mA 500v AC between any open terminal for one minute

Lifetime:

Withstand more than 5000 cycle's insertion and withdrawal with testing plug

Rated Voltage:

16vdc

Rated Current:

20mA - 0.3A

OUTLINE DRAWING

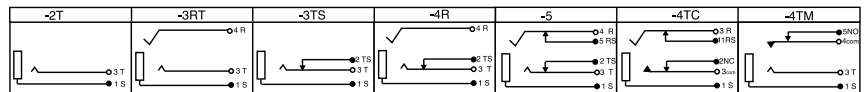
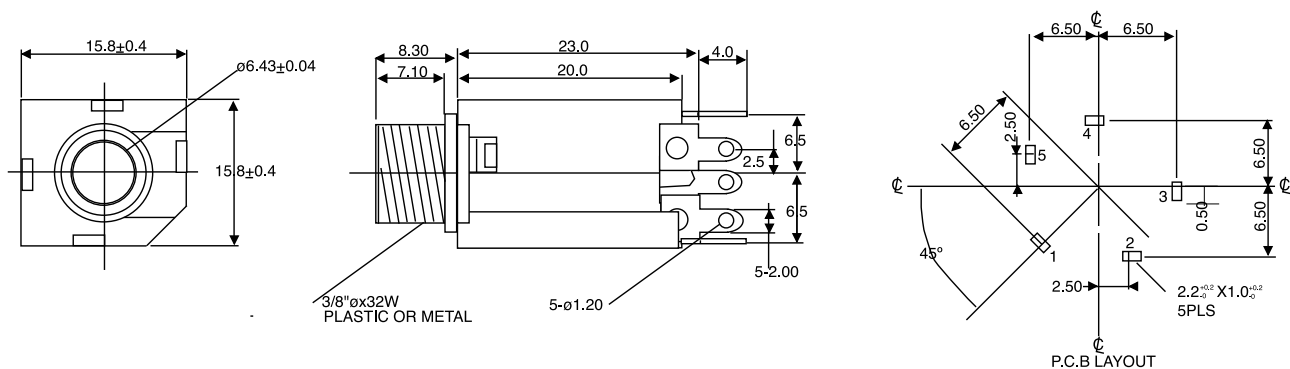

ORDERING INFORMATION

DBC	HJ	0695		-2T
Dubilier Connectors	6.4Ø Earphone Socket Connector	Series	Bushing	Contacts
			Blank = Plastic M = Metal	-2T -3RT -3TS -4R -4TC -4TM -5

AUDIO

- Competitively priced
- Industry Compatible
- PCB Mounting or Wire Soldering

PCB 6.4Ø HEADPHONE JACK



SPECIFICATION

Contact resistance (DCR 0.1A)

1, Initial, before any testing:

- (1) Between the terminals (NC): 30mΩ
- (2) Plug to sleeve, tip ,ring (NO) contact: 50mΩ

2, After life test with mating plug:

- (1) Between the terminals (NC): 60mΩ
- (2) Plug to sleeve, tip, ring (NO) contact: 100mΩ

- Insertation Force:** 0.3kg - 3.0kg Terminals must withstand a 500g minimum pull for 10 seconds
- Extraction Force:** 0.3kg - 3.0kg before movement or break from housing occurs
- Soldering Heat:** Terminal for PC board temperature: 260 ± 5 °C for 5 ± 1.0 seconds
- Operating Temperature range:** -25 °C to 100 °C
- Insulating Resistance:** More than 100MΩ by 500v DC at 90 - 95% RH, 40 °C
- Voltage Test:** Withstand 0.5mA 500v AC between any open terminal for one minute
- Lifetime:** Withstand more than 5000 cycle's insertion and withdrawal with testing plug
- Rated Voltage:** 16vdc
- Rated Current:** 20mA - 0.3A

OUTLINE DRAWING

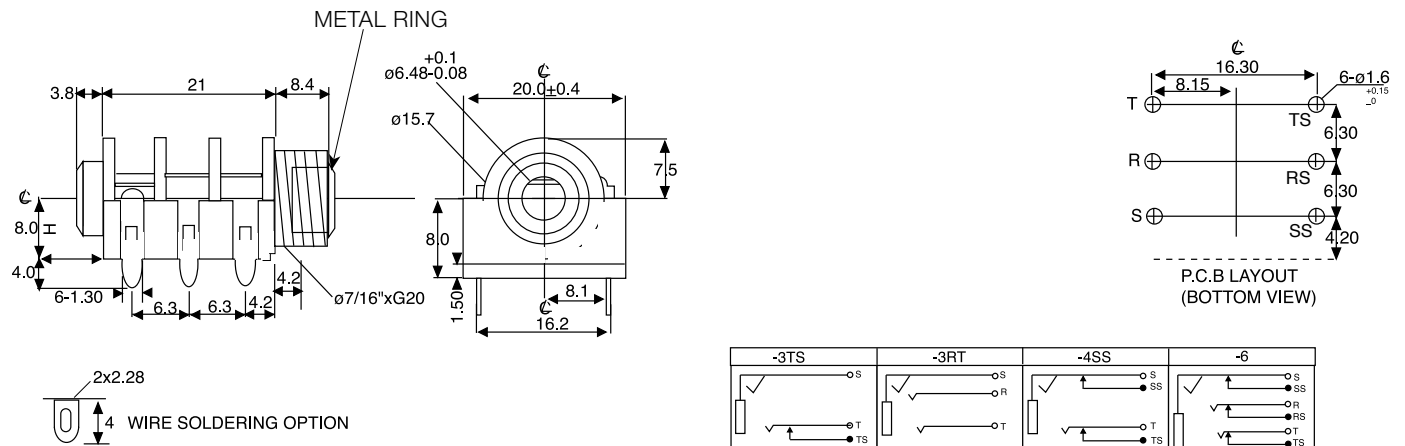

ORDERING INFORMATION

DBC	HJ	0661		-3TS
Dubilier Connectors	6.4Ø Headphone Socket Connector	Series	Pin Configuration	Contacts
			Blank = PCB Type	-3TS
			S = Wire Soldering	-3RT
				-4SS
				-6

